



STAINLESS STEEL EVERYDAY BUFFET FROST TOP WITH SOLID BASE

FEATURES:

- High nominal cooling capacity. (1500 btuh) for guaranteed product temperature control
- Aluminum encased copper tube evaporator panels improve heat transfer by increasing contact area
- This increases operating efficiency and reduces power consumption
- Expansion valve for efficient operation at various temperature conditions
- Refrigerant filter drier to insure cleanliness of sealed refrigeration circuit
- Sight glass to insure a properly charged refrigeration system
- Liquid receiver for improved refrigerant charge control.
- Low running current suitable for any 115 volt circuit.
- Precision electronic thermostat for exact temperature control.
- Switched 115 VAC receptacles to power condensing unit and remote ventilation fan. (optional)
- Removable access door to compressor
- 4" Swivel Casters, with two brakes
- Double sided sneeze guard
- Solid tray shelf (1) TTS included

MATERIAL:

TOP: 16 gauge #304 stainless steel welded construction
BODY: 20 gauge steel available in matte black vinyl clad

SNEEZE GUARD: 1/4" Lexan®

INSULATION: Fiberglass insulation

LINERS: 18 gauge, 304 stainless steel, one piece construction, all welded, ground and polished to a uniform finish

All corners are covered with a 1/4" radius

REFRIGERATION SYSTEM:

The compressor is housed in a 16 gauge galvanized under structure, fabricated from formed angles and bolted to the galvanized jacket. The fully self contained condensing unit is provided with a hermetically sealed compressor with a digital, programmable thermostat. The system is fully charged with environmentally friendly R404-A refrigerant

ELECTRICAL:

Unit will be wired for 15 amps, 120V single phase operation with an on/off thermostat switch

115 V, 8 AMPS, 60 Hz, 1/4 HP

Includes 6 ft. long, 3 wire cord with a NEMA 5-15P plug

PLUMBING:

Two 1" I.P.S. drains



Item #:	_____	Qty #:	_____
Model #:	_____		
Project #:	_____		



BF3-B-SB Shown

NOTE: Units are not designed to cool foods originally warm. Food should already be chilled to maintain the proper temperatures

Model	Length	Width	Work Area Length (A)	Height	Refrigerant	Wt (lbs.)	Cu. Ft.
BFT2-B-SB	31.8125"	22.625"	26.8125"	56.15"	R404-A	245	43
BFT3-B-SB	47.125"	22.625"	41.6875"	56.15"	R404-A	320	62
BFT4-B-SB	62.4375"	22.625"	57"	56.15"	R404-A	400	79
BFT5-B-SB	77.75"	22.625"	72.3125"	56.15"	R404-A	485	97



Customer Service Available To Assist You 1-800-645-3166 8:30 am - 8:00 pm E.S.T.

For Orders & Customer Service:

Email: customer@advancetabco.com or Fax: 631-242-6900

For Smart Fabrication™ Quotes:

Email: smartfab@advancetabco.com or Fax: 631-586-2933

DIMENSIONS and SPECIFICATIONS

TOL ± .125"

ALL DIMENSIONS ARE TYPICAL

SIDE VIEW

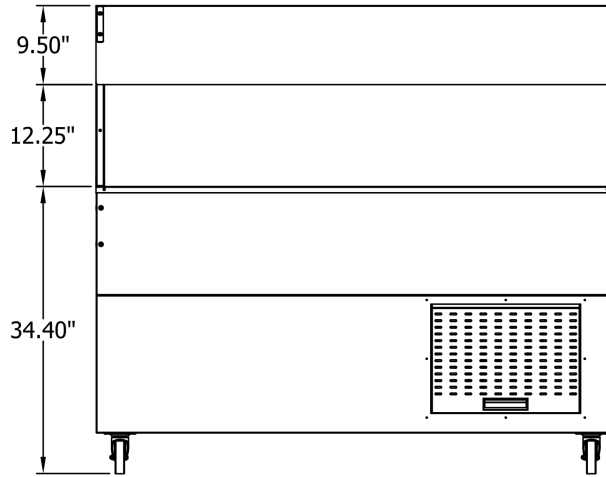
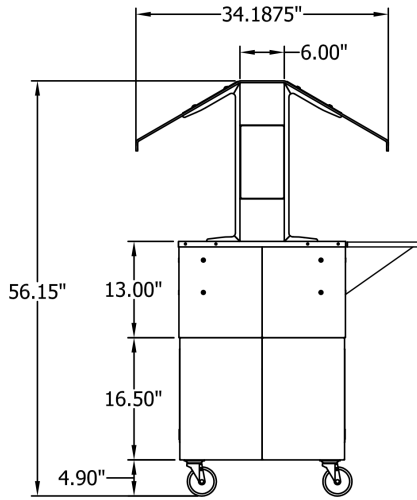
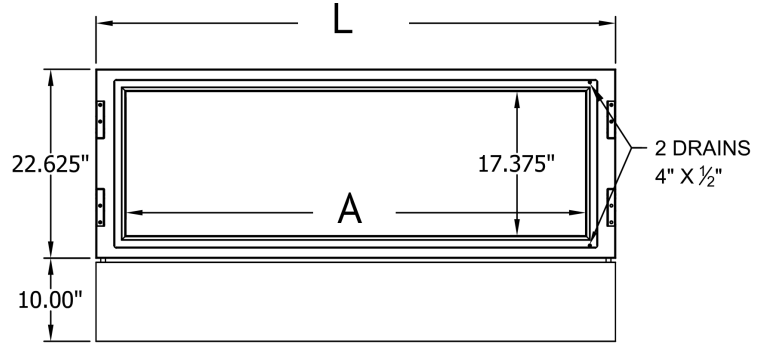

Available Accessories

- Solid Tray Shelf - **Models TTS-(2-5)**
- Drop Down Solid Tray Shelf - **Models TTS-(2-5)D**
- Tubular Tray Rail - **Models TTR-(2-5)**
- Drop Down Tubular Tray Rail - **Models TTR-(2-5)D**
- Stainless End Shelf - **Model BES-2**

Optional Bullet Lights

Heat lamps installed and pre wired on Buffet Tables. 120 volt plug and cord supplied. Lamps finished in black only. (Bulbs by Others)

Lamp Model	Use with Model:
HL-2	B2-CTU-SB
HL-3	B3-CTU-SB
HL-4	B4-CTU-SB
HL-5	B5-CTU-SB



NEMA PLUG
5-15P



ADVANCE TABCO is constantly engaged in a program of improving our products. Therefore, we reserve the right to change specifications without prior notice.