



BIZERBA
 ... closer to your business

VS 12 – the adjustable product support ensures neat and perfect slicing.

... VS 12 – for perfect slicing ...



VS 12

- 13" blade
- Maximum product size: rectangular = 10.2" x 8.8", round = 8.8"
- Particularly suited for cutting: ham, bacon, roast joints, roast beef, fresh meat, crisp vegetables and bread
- Remarkably robust and extremely hardwearing
- Easy access for cleaning between motor block and blade
- This food machine is used in supermarkets, deli departments, butchers, bakeries and within the catering services
- Top quality horizontal carriage with positive feed

Best blade in the industry

The unique design of our blade produces clean and consistent slices. The hardness results in a long lasting sharp edge. The life of the blade is dramatically longer than the competition. Our standard blade is the hardest, thinnest, largest, straightest blade in the industry.

- 13" diameter, chromium coated hard alloy
- 60-62 Rockwell hardness at the edge

Optional accessory:

Easy to adjust product clamp for problem free slicing down to the smallest end piece.



Project Name _____
 Model/s _____
 Number _____
 Quantity _____

BIZERBA

... closer to your business

1-phase AC current

- 120/230 V, specialised data available on request
- 60/50 Hz
- Frequency of nominal current 2.42/1.8 A
- Power consumption 0.165/0.350 kW

3-phase AC current

- 230/400 V, specialised data available on request
- 50 Hz
- Frequency of nominal current 1.2/0.68 A
- Power consumption 0.310 kW

Blade diameter

- 13" (330 mm)

Blade speed

- 266 r.p.m.

Max. produce size

- Round: 8.8" (224 mm)
- Rectangular: 10.2 x 8.8" (260 x 224 mm)

Slice thickness

- 0-0.9" (0-24 mm), infinitely variable

Installation area

- (L x W) 20.5 x 16.9" (520 x 430 mm)
 (reduced) 11.8 x 16.5" (300 x 420 mm)

External dimensions

- (L x W x H) 24.6 x 21.9 x 17" (625 x 555 x 432 mm)

Operating area

- (L x W) 26.5 x 29.1" (672 x 740 mm)

Protection type

- IP 33

Weight of machine

- 89 lbs, 40,4 kg

Packing case

- 32.7 x 27.6 x 25.2" (830 x 700 x 640 mm)
 Weight 107.8 lbs (49 kg)

Additional equipment

- Product fixing fence, oblique slicing equipment, Teflon blade, stop plate and blade guard with non-stick coating

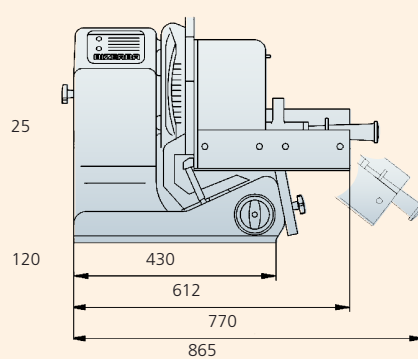
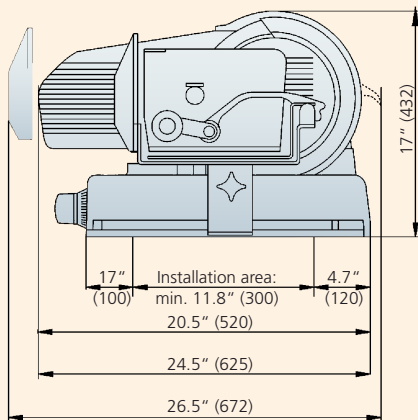
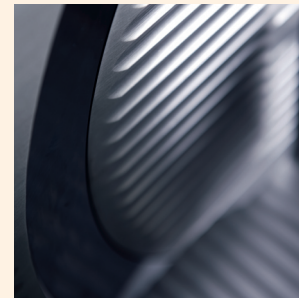

Warranty

The VS 12 carries a one-year, on-site parts and labor warranty against any flaws in materials and workmanship. This period begins with the date of purchase and, provided the unit is used properly in accordance with our instructions, is in full effect for one year from that date. Any work to be performed under this warranty must be performed between the hours of 8:00 a.m. and 4:30 p.m. local time, Monday to Friday. Bizerba will not pay overtime charges for work performed other than during normal business hours. Accessories have a 30-day replacement or repair warranty for the period beginning on the date of purchase. Damages incurred in transit or from installation error, accident, alteration or misuse are not covered. Transit damages should be reported to the carrier immediately. Bizerba shall not be liable for any consequential, compensatory, incidental, or special damages. All warranty work must be performed by a factory authorized Bizerba Representative.

Members of the Bizerba Group

Bizerba GmbH & Co. KG
 Wilhelm-Kraut-Straße 65
 72336 Balingen
 Germany
 Tel. +49 7433 12-0
 Fax +49 7433 12-2696
 marketing@bizerba.de
 www.bizerba.com

Bizerba USA Inc.
 31 Gordon Road
 Piscataway
 New Jersey 08854
 USA
 Tel. Office +1 732 565-6000
 Tel. Service +1 732 565-6001
 Fax +1 732 819-0429
 us.info@bizerba.com
 www.bizerbausa.com

Bizerba Canada Inc.
 2810 Argentinia Road #9
 Mississauga,
 Ontario L5N 8L2
 Canada
 Tel. +1 905 816-0498
 Fax +1 905 816-0497
 sales@bizerba.ca
 www.bizerba.ca

Bizerba de México, S.A. de C.V.
 Av. Rio Mixcoac No. 157
 Colonia Florida
 01030 México, D.F.
 México
 Tel. +52 55 5663-1397
 Fax +52 55 5663-1296
 eduardo.aburto@bizerba.com.mx
 www.bizerba.com.mx