

For Foodservice Applications

Job Name _____
 Job Location _____
 Engineer _____
 Approval _____

Contractor _____
 Approval _____
 Contractor's P.O. No. _____
 Representative _____

LEAD FREE*



**Series QT™ Brew Max™
 Brew Station Filtration Systems**

Flow Rate: 1.5 to 3 GPM (5.7 to 11.4 LPM)

Hydro-Safe® QT Brew Max systems have been specifically engineered to address and correct multiple water related problems for brew stations. Incorporating both premium grade carbon filtration with poly-phosphate media for scale control, these systems deliver superior filtration while providing advanced scale protection. Advanced carbon filtration for the reduction of lead, cyst and VOC in addition to chlorine taste and odor providing a superior consistent quality beverage. Filter cartridge replacement is quick, easy, and sanitary because of the encapsulated design. The Hydro-Safe QT Brew Max features Lead Free* construction to comply with Lead Free* installation requirements.

Applications

- Coffee Brewers
- Tea Machines
- Soda Machines

Features

- Simple filter replacement using QT cartridges
- Increases brew machine life, performance and quality
- Reduces scale build-up
- Reduces lead, cyst, VOC's, sediment, chlorine taste and odor
- Reduces maintenance and system downtime
- Consistent quality and better tasting drinks
- In/Out valves allow for easy filter service
- Flush kits are standard on all models
- Pressure gauges are included on all two stage and larger systems
- Easy to install



QTBRWMAX-1S-1M



QTBRWMAX-2S-1M



QT Brew Max Systems have been tested and certified according to NSF/ANSI 42 for reduction of the substances listed below. The concentration of the indicated substances in water entering the system was reduced to a concentration less than or equal to the permissible limit for water leaving the system, as specified in NSF/ANSI 42. These systems have been tested and certified according to NSF/ANSI Standard 372 for "lead free" compliance.

⚠ WARNING

Do not use with water that is microbiologically unsafe or of unknown quality without adequate disinfection before or after the system.

*The wetted surface of this product contacted by consumable water contains less than 0.25% of lead by weight.

Watts product specifications in U.S. customary units and metric are approximate and are provided for reference only. For precise measurements, please contact Watts Technical Service. Watts reserves the right to change or modify product design, construction, specifications, or materials without prior notice and without incurring any obligation to make such changes and modifications on Watts products previously or subsequently sold. Refer to the owner's manual for warranty information.



System Specifications

Maximum Pressure: 100 psi/6.8 bar
 Minimum Pressure: 20 psi/1.4 bar
 Maximum Temperature: 100°F/38°C
 Minimum Temperature: 40°F/4.4°C
 Feed Water Quality: pH 6.5 to 8.5
 Chlorine < 2ppm

Iron (maximum) 0.3 mg/l
 Manganese (maximum) 0.05 mg/l
 Oil & H₂S- None allowed

For all other feed water quality requirements abide by the current USEPA Safe Drinking Water Act standards.

Filter Cartridge Life Span

Filter cartridges should be changed at end of filter life, due to lack of filtering performance, or whenever a 15 psi pressure drop or greater is experienced during normal operation, whichever comes first.

System Model	Max Flow Rate	Chlorine Capacity*	Connection Size	Reduces				
				Sediment	Chlorine*	Scale	Lead	Chloramine
QTBRWMAX-1S-1M	1.5 GPM (5.7 LPM)	10,000 Gallons	3/8" (10mm) NPT	✓	✓	✓	✓	✓
QTBRWMAX-2S-1M	3 GPM (11.4 LPM)	20,000 Gallons	1/2" (15mm) NPT	✓	✓	✓	✓	✓

*Chlorine capacity and chlorine reduction was Tested and Certified by WQA against NSF/ANSI standard 42. Testing was conducted with water having an influent challenge concentration of 2.0 mg/L (± 10%) free chlorine and an effluent reduction requirement of equal to or greater than 50%. Testing was performed under standard laboratory conditions, actual performance may vary. Other contaminant reduction claims are non certified.

System Replacement Filters			
System Model	Filter Ordering Code	Frequency	Description
QTBRWMAX-1S-1M	QTBR15S**	6 Months	15" 1 Micron Carbon Block for Lead Reduction with Phosphate Scale Control
QTBRWMAX-2S-1M	QTBR15	6 Months	15" 1 Micron Carbon Block for Lead Reduction with Phosphate Scale Control (2)

NOTICE

Cartridge capacities are estimates and may be less depending on incoming water quality. Once installed, flush new cartridges for 5 minutes prior to use for proper conditioning.

**The QTBR15S is the same filter as the QTBR15. Only the label position has been changed so that the label faces forward on single cartridge systems."

System Diagrams

QTBRWMAX-1S-1M

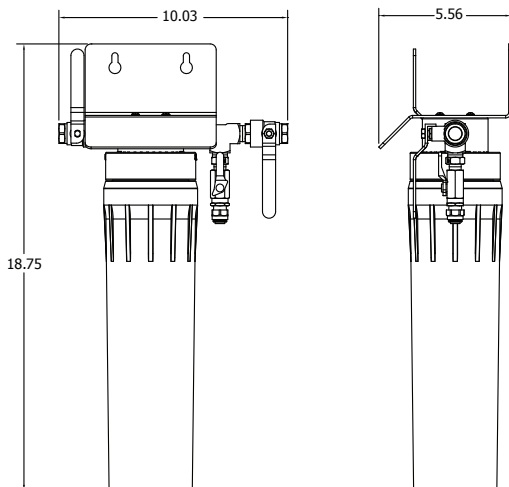

QTBRWMAX-2S-1M

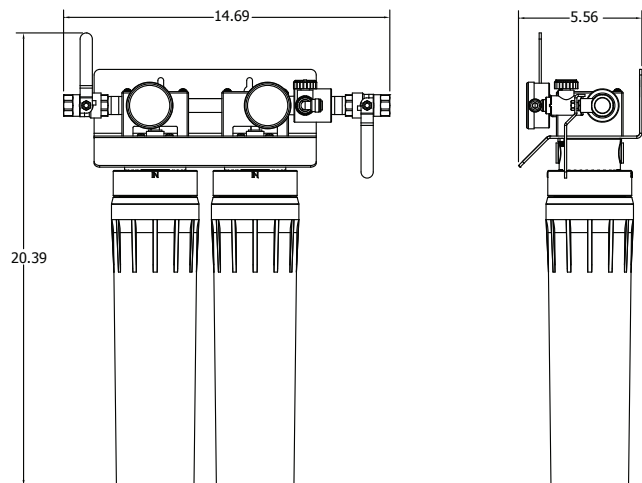

Note: Allow 3" of clearance at bottom of system for removal of filter bowls for filter cartridge replacement



A Watts Water Technologies Company



Tel: (800) 264-1183 • Fax: (724) 733-4808 • foodservice.watts.com