



Profit from the Eagle Advantage®

Specification Sheet

Short Form Specifications

Eagle Spec-Master® FNP Series Three-Compartment Prep Sink, model _____. Unit constructed of 14/304, 18-8 stainless steel throughout. Sink bowls fabricated with a 5/8" radius, with 14" water level. Drainboard "V" creased for positive drainage. Prep area with 6"-wide slanted trough and two flush nozzles. 9 1/2" high backsplash with 1" upturn and tile edge. Legs to be 1 1/2" O.D., stainless steel, with stainless steel gussets, stainless steel crossbracing and adjustable stainless steel bullet feet.

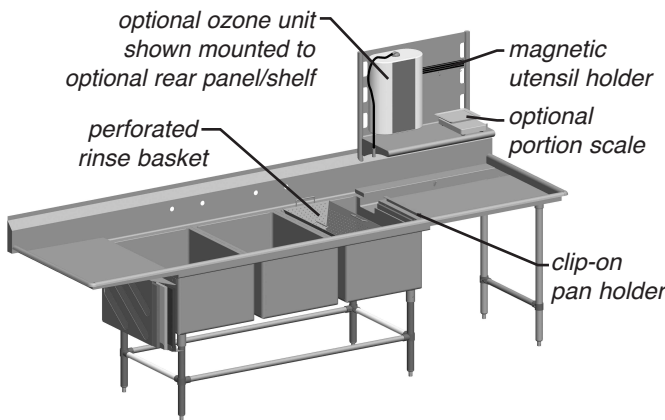

"R" model with trough and prep area at right end — shown with optional ozone unit

Options / Accessories

- Lever drain
- Lever drain with overflow
- Twist handle drains
- Overflow hole
- Sink kits
- Faucets
- Polyboard sink covers
- Stainless steel sink covers
- Disposer collar
- Disposer switch bracket
- Undercounter refrigeration
- Waste disposal unit
- Trough nozzle flow controls
- Additional trough locations
- Portion scale
- Ozone unit
- Rear panel/shelf (factory-installed through backsplash)

Features:

- Sink with prep area.
- Multi-polyboard assembly, affixed to sink bowl in drainboard area, includes three colored polyboards.
- Includes magnetic utensil holder, custom-fit rinse basket, and removable bun pan holder.

EAGLE GROUP

100 Industrial Boulevard, Clayton, DE 19938-8903 USA
Phone: 302-653-3000 • Fax: 302-653-2065
www.eaglegrp.com

Foodservice Division: Phone 800-441-8440

MHC/Retail Display Divisions: Phone 800-637-5100

For custom configuration or fabrication needs, contact our SpecFAB® Division.

Phone: 302-653-3000 • Fax: 302-653-2065 • e-mail: quotes@eaglegrp.com

Item No.: _____
 Project No.: _____
 S.I.S. No.: _____

Spec-Master® FNP Series Coved Corner Three-Compartment Prep Sinks

MODELS:

- FNP2860-3-48TR
- FNP2860-3-48TL
- FNP2860-3-1848TR
- FNP2860-3-1848TL
- FNP2860-3-2448TR
- FNP2860-3-2448TL

Top:

- Prep area with 6" (152mm)-wide slanted trough supplied with two flush nozzles.
- Optional rear panel/shelf is factory-installed through backsplash in prep area of sink (see illustration).
- Drainboard, prep area, backsplash and rolled rims are integrally welded 14 gauge type 304 stainless steel.
- All rolled edges are highlighted for enhanced appearance.
- 9 1/2" high backsplash with 1" upturn and tile edge.
- 1 1/2" (29mm) faucet holes punched on 8" (203mm) centers.

Base:

- Legs: 1 1/2" (41mm)-diameter stainless steel tubing with stainless steel gussets and fully adjustable stainless steel bullet feet.
- Crossbracing: Adjustable, 1 1/4" (32mm)-diameter stainless steel; running left-to-right and front-to-back.
- Leg locations fall directly under sink bowl, providing increased stability and maximum weight support.
- Additional leg locations and crossbracing under prep area and drainboards longer than 24" (610mm).
- Leg gussets welded to a die-cut heavy-gauge stainless steel reinforcing corner plate.

Sink Bowls:

- 14 gauge type 304 stainless steel.
- 14" (356mm) water level, 17" (432mm) flood level.
- Sink compartments fabricated with a 5/8" (41mm) radius, using state-of-the-art seamless welding techniques.
- Basket-type waste drain fits sink bowl's 3 1/2" (89mm) opening and features 1 1/2" (38mm) outlet.

Certifications / Approvals



AUTOQUOTES



EG20.62 Rev. 10/14

Spec sheets available for viewing, printing or downloading from our online literature library at www.eaglegrp.com

Eagle Foodservice Equipment, Eagle MHC, SpecFAB®, and Retail Display are divisions of Eagle Group. ©2014 by the Eagle Group



Item No.: _____
 Project No.: _____
 S.I.S. No.: _____

Spec-Master® FNP Series Coved Corner Prep Sinks —Three-Compartment

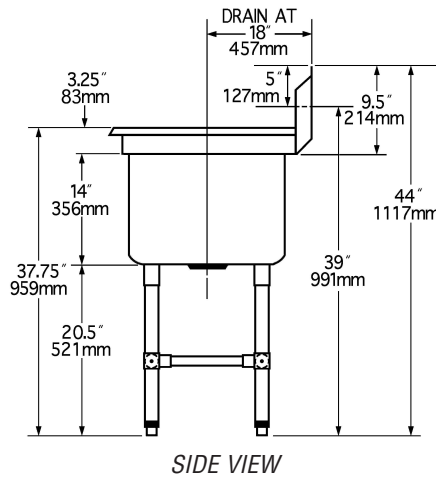
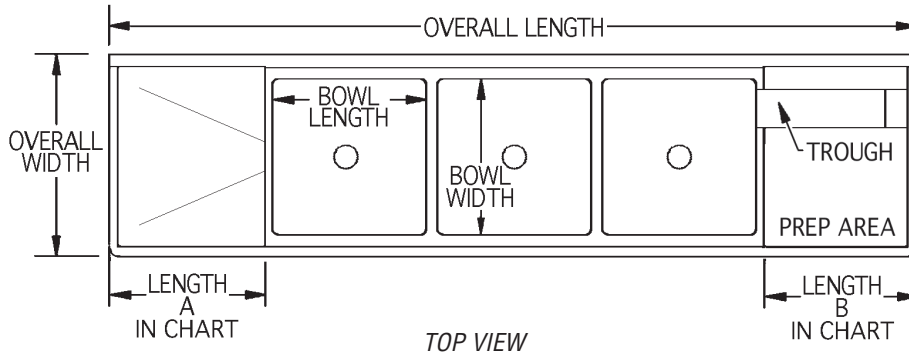

| model # | trough & prep area located | BOWL DIMENSIONS | | | | DRAIN-BOARD | | PREP AREA | | OVERALL DIMENSIONS | | | |
|------------------|----------------------------|-----------------|-----|--------|-----|-------------|-----|-----------|------|--------------------|-----|--------|------|
| | | width | | length | | LENGTH A | | LENGTH B | | width | | length | |
| | | in. | mm | in. | mm | in. | mm | in. | mm | in. | mm | in. | mm |
| FNP2860-3-48TL | at left end | 28" | 711 | 20" | 508 | n/a | | 48" | 1219 | 35" | 889 | 115½" | 2934 |
| FNP2860-3-48TR | at right end | 28" | 711 | 20" | 508 | n/a | | 48" | 1219 | 35" | 889 | 115½" | 2934 |
| FNP2860-3-1848TL | at left end | 28" | 711 | 20" | 508 | 18" | 457 | 48" | 1219 | 35" | 889 | 132" | 3353 |
| FNP2860-3-1848TR | at right end | 28" | 711 | 20" | 508 | 18" | 457 | 48" | 1219 | 35" | 889 | 132" | 3353 |
| FNP2860-3-2448TL | at left end | 28" | 711 | 20" | 508 | 24" | 610 | 48" | 1219 | 35" | 889 | 138" | 3505 |
| FNP2860-3-2448TR | at right end | 28" | 711 | 20" | 508 | 24" | 610 | 48" | 1219 | 35" | 889 | 138" | 3505 |

Units with 30" and 36" drainboards ("LENGTH A") also available.

EAGLE GROUP
 100 Industrial Boulevard, Clayton, DE 19938-8903 USA
 Phone: 302-653-3000 • Fax: 302-653-2065
 www.eaglegrp.com

Foodservice Division: Phone 800-441-8440
 MHC/Retail Display Divisions: Phone 800-637-5100

Printed in U.S.A.
 ©2014 by Eagle Group

Rev. 10/14

Spec sheets available for viewing, printing or downloading from our online literature library at www.eaglegrp.com

Although every attempt has been made to ensure the accuracy of the information provided, we cannot be held responsible for typographical or printing errors. Information and specifications are subject to change without notice. Please confirm at time of order.