



701 S Ridge Avenue, Troy, OH 45374
1-888-4HOBART • www.hobartcorp.com

ACCESS PREPACK SYSTEM



STANDARD FEATURES

Operator Mode

- Large color touch screen display (10.4")
- Search database by description or nearest PLU number
- Flashkeys can be set up by categories or classes
- Go to keys allows user to jump immediately to a location instead of going through a menu tree
- Calendar for setting date and time
- Product and shelf life by day and/or hour
- Programmable display of operator viewable fields
- Operator notes and product notes
- Onscreen help questions and answers
- Pop-up alphanumeric keyboard/numeric keypad

Supervisor Mode

- Onscreen help questions and answers
- USB port can support external keyboard
- Graphics can be named instead of just numbered
- Visual display of database records
- System can estimate the number of additional records that may be added to the scale
- COOL records can be created on the scale
- User definable defaults for item record values
- Ability to renumber PLU records
- Database can be backed up to USB drive
- Database can be named to store more than one database to flash drive

MODEL

- EPP – Access Prepack Printer
- EPCP – Access Prepack Control Panel

ACCESSORIES

- ULTIMASA-1 – Stand Alone Scale
- ACCESS-UWSKIT – UWS Conversion Kit
- ACCESS-MUKIT – UWS Manual Kit
- ACCESS-HWSKIT – Hand Wrap Station Kit
- ACCESS-SAKIT – Stand Alone Kit
- ACCESS-CLAKIT – CLA Conversion Kit
- ACCESS-ILAKIT – ILA Conversion Kit

Specifications, Details and Dimensions on Inside and Back.



Stand-Alone

ACCESS PREPACK SYSTEM

ACCESS PREPACK SYSTEM

HOBART

701 S Ridge Avenue, Troy, OH 45374
1-888-4HOBART • www.hobartcorp.com

COMMUNICATIONS

- Functions as a web browser: simply plug into your hard-wired or wireless connection to access the internet or your own custom web site
- 10/100 Ethernet support (wired) standard
- TCP/IP Wireless (RF card not included)
- System firmware can be upgraded via a USB flash drive or over a local or wide area network
- Remote access via an IP address over a local or wide-area network using Internet Explorer
- Compatible with current Ultima and Quantum Scale Management Programs using TCP/IP

HARDWARE

- PC based architecture
- Intel/Celeron processor
- Standard laptop RAM, 128 MB of memory
- Standard CompactFlash for DB backup (no need for battery backup)
- PC card slot for wireless card support
- 1 PCI slot for future expansion
- USB ports for peripherals and future expansion
- Optional USB computer type keyboard allows for easy data entry

MERCHANDISING

- More dots per inch printhead for higher resolution graphics and smaller bar codes – 203 dpi vs. 144 dpi (8 dots per mm vs. 6 dots per mm)
- Product life and shelf life can be managed by days and/or by hours
- Four programmable graphics per PLU
- Up to 3 levels of frequent shopper prices/discount fields
- Operator and Product notes
- Expanded text and special message fields have unlimited length
- Uses standard file formats: PNG for label graphics, JPEG and GIF for screen graphics, and TTF font formats
- EAN Bar Code available for packages over \$99.99 total price
- Same label stock as Ultima/Quantum scales
- 1½", 2¼" and 3" wide labels up to 4" length for auto-apply
- Accepts up to 8" long labels for hand application



Fully Automatic AWS



701 S Ridge Avenue, Troy, OH 45374
1-888-4HOBART • www.hobartcorp.com

ACCESS PREPACK SYSTEM

SERVICEABILITY

- Every operator/supervisor screen is a web page that can be accessed remotely via Internet Explorer
- Diagnostics information can be retrieved; scale configuration and PLU database can be verified or modified
- Monitor real-time use of the scale
- System firmware can be upgraded via a USB flash drive or network
- See statistics on the system (real time updates of mem free in flash, RAM, RamDisk, EVM)
- Automatically send emails when the system is out of labels or when the cassette/print head is disengaged for a given period of time
- Onscreen help questions and answers

SPECIFICATIONS

Access EPP Printer:

120/60/1, 1.25 Amps, 150 Watts
26.05 lbs. shipping weight

Access EPCP Control Panel:

120/60/1, .50 Amps, 65 Watts
15.9 lbs. shipping weight

NOTICE: Fluorescent lamp in display panel contains a small amount of mercury. Please dispose of according to local, state or federal laws.

Weigher Capacity:

30 lb. x .01 lb. (30.09 maximum) or
50 lb. x .01 lb. (50.09 maximum)

Pricing Capacity:

Up to 999.99 in steps of .01



Fully Automatic AWS



Hand Wrap Station HWS



Semi-Automatic AWS

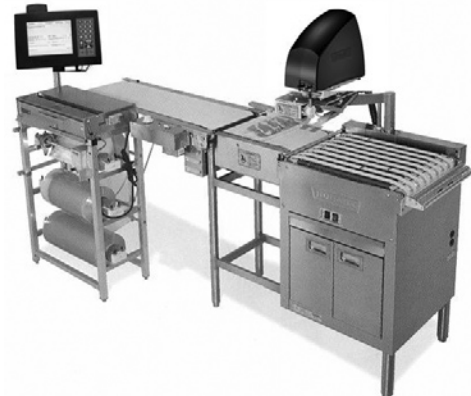

Semi-Automatic CLA System

ACCESS PREPACK SYSTEM



701 S Ridge Avenue, Troy, OH 45374
1-888-4HOBART • www.hobartcorp.com

DETAILS AND DIMENSIONS

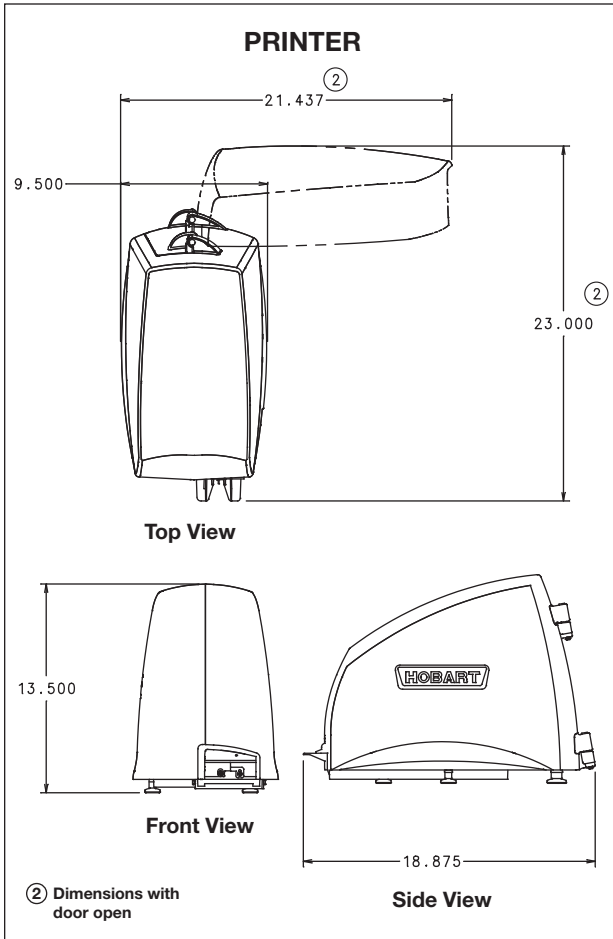
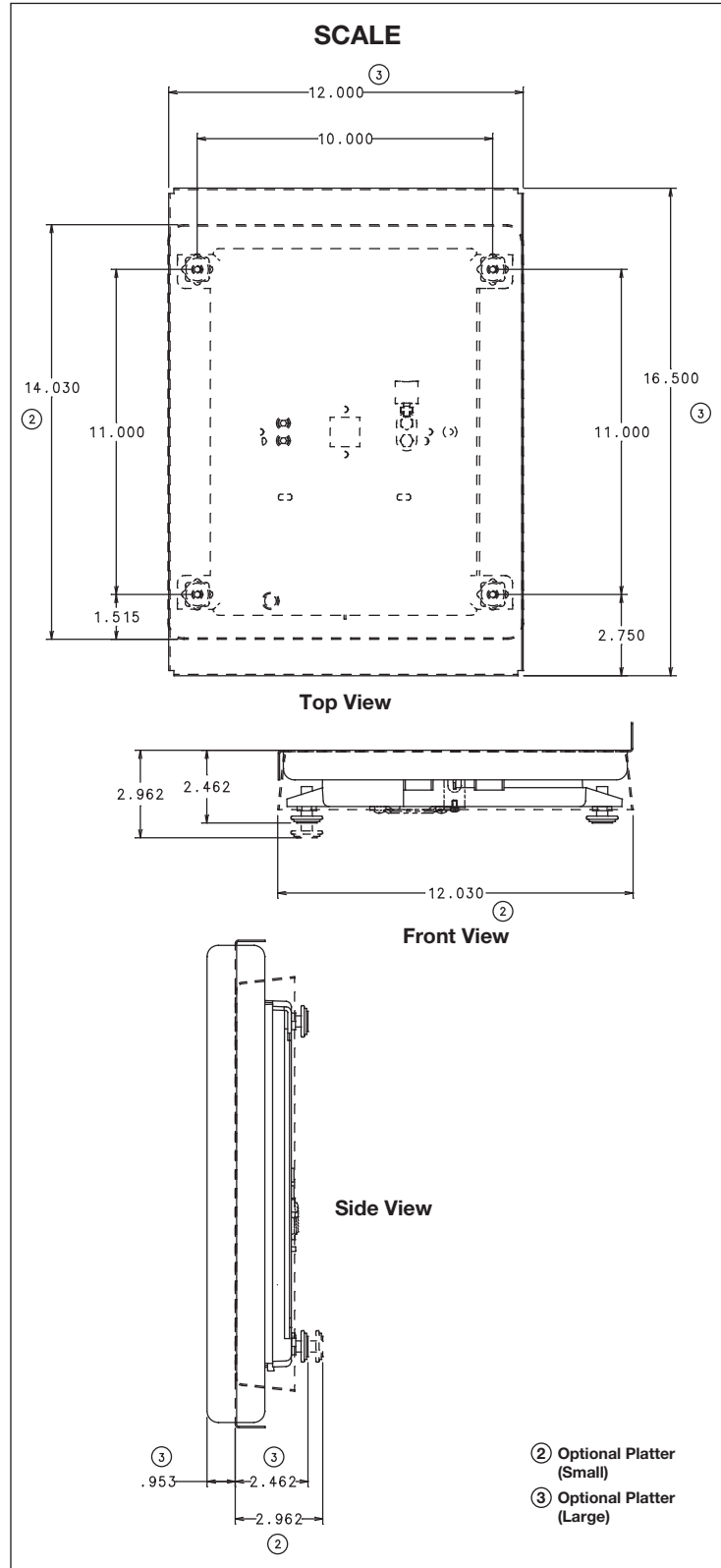
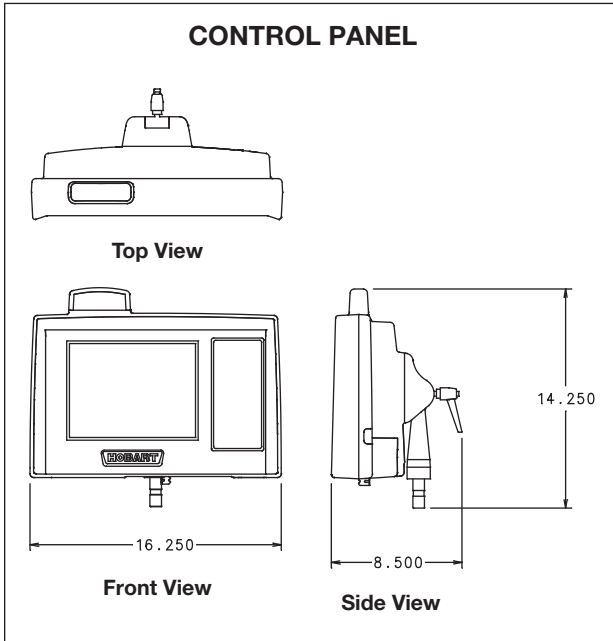

As continued product improvement is a policy of Hobart, specifications are subject to change without notice.