



(Shown on optional 36" cabinet base and digital controls)

SPECIFICATIONS:

Shall be a Model **ECX-2** electric convection steamer with electric steam boiler. The steamer shall be constructed of satin finish stainless steel, type 304, with a cooking chamber of one-piece all-welded stainless steel. The doors shall have a removable inner liner of stainless steel with full perimeter gasket seal, an outer liner of one-piece all welded stainless steel, and a positive lock and seal mechanism with spring release. The door opening shall be 10" x 14" (254 x 356 mm). The steamer shall be provided with removable stainless steel pan supports and a stainless steel drip trough connected to drain to collect condensate when door is opened.

The control housing shall be constructed of stainless steel with a full access removable panel. The controls shall include an illuminated on/off power switch. The timing of each compartment shall be independently controlled by a pilot ready light, a pilot cooking light and a 60 minute electric timer which sounds an audible signal at the end of the cooking cycle. Steam flow to the chamber shall be cut off when the door is opened during the cooking cycle and shall be reactivated when the door is closed.

The convection steamer shall be mounted on a cabinet base with full perimeter angle frame, reinforced counter and boiler mountings, electric boiler with controls, all stainless steel exterior, hinged doors and 6" (152 mm) stainless steel legs with adjustable bullet feet.

Model	Compartments	Capacity
ECX-2	2	4-12 Pans

OPERATION SHALL BE BY:

Electrically heated steam boiler operating at 15 psi (103 kPa) and rated at:

- 24.0 kw (standard)
- 36.0 kw
- 42.0 kw
- 48.0 kw

The steam boiler shall be equipped for operation on:

- 208 VAC, 3 Phase, 60 Hz
- 230 VAC, 3 Phase, 60 Hz
- 240 VAC, 3 Phase, 60 Hz

The controls shall be equipped for operation on 115VAC, 1 Phase, 60 Hz

OPTIONAL ITEMS AT EXTRA COST:

- Solid state digital controls
- Automatic boiler blow down
- 220 or 240 VAC, 1 Phase, 50 Hz
- Two water lines (boiler feed and condensate)
- De-lime piping assembly (DPA-1)
- Stainless steel frame
- Cabinet size (36", 48")
- Stainless steel back on cabinet
- California State boiler code requirement
- CSD-1
- 380 VAC, 3 Phase, 50 Hz
- 415 VAC, 3 Phase, 50 Hz
- 480 VAC, 3 Phase, 60 Hz
- Correctional package

ACCESSORIES:

- Spray and rinse assembly
- 12" x 20" x 2.5" perforated stainless steel pan
- 12" x 20" x 2.5" solid stainless steel pan
- 12" x 20" x 4" perforated stainless steel pan
- 12" x 20" x 4" solid stainless steel pan
- Adjustable flanged feet
- Ball float trap
- Water in strainer
- Steam take-off kit



Models: ECX-2

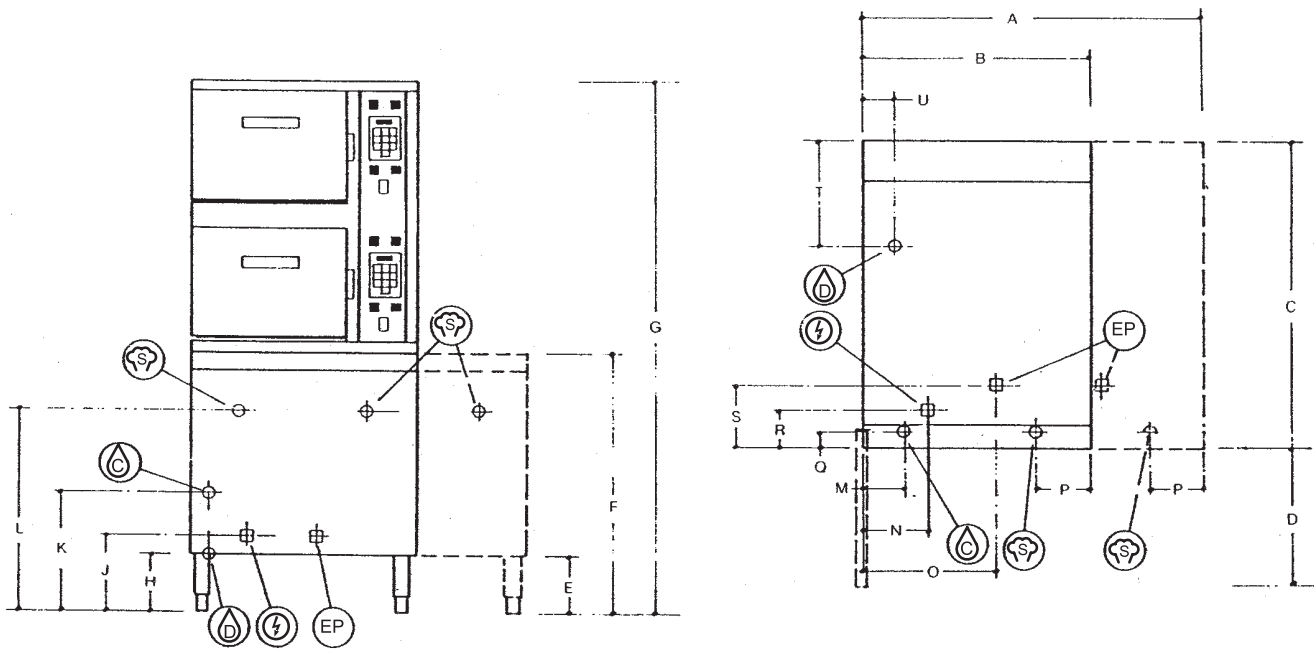

DIMENSIONS

Model	Units	A	B	C	D	E	F	G	H	J	K	L	M	N	O	P	Q	R	S	T	U
ECX-2	in (mm)	36" (914)	24" (608)	33" (838)	14" (357)	6" (152)	28" (711)	58" (1479)	6" (152)	8" (203)	14" (357)	22" (559)	5" (127)	6" (152)	4" (102)	6" (152)	2" (51)	4" (102)	6" (152)	11" (279)	5" (127)

ELECTRICAL CHARACTERISTICS

MODEL	208V		230V		240V		380V		415V		480V	
	kW	AMPS	kW	AMPS	kW	AMPS	kW	AMPS	kW	AMPS	kW	AMPS
ECX-2	28	66.6	24	60.3	24	57.8	24	36.5	24	33.4	24	28.9
	36	100.0	36	90.4	36	86.7	36	54.7	36	50.1	36	43.3
	42	116.6	48	120.6	48	115.6	48	73.0	48	66.8	48	57.8

SERVICE CONNECTIONS

EP - Electric power connection to boiler: Sized for at least 90°C per line.

C – COLD WATER: 1/2" (13 mm).

D – DRAIN: 2" (51 mm) IPS piped to open floor drain. No solid connection.

E – ELECTRICAL CONNECTION: 1/2" (13 mm) conduit connection to controls. 2 Amps per compartment, 120-60-1 or 220-50-1.

S – STEAM TAKE-OFF CONNECTION: 3/4" (19 mm) optional to operate adjacent equipment.

**INTENDED FOR COMMERCIAL USE ONLY.
NOT FOR HOUSEHOLD USE.**